

- ✓ **Input for 1k Ω to 100k Ω Potentiometers**
- ✓ **Two independent Outputs**
Current Output 4-20mA
Voltage Output 0-10V
- ✓ **Fast response Time**
- ✓ **For 35 mm DIN - rails**
- ✓ **Supply 24V DC**

OC35P-DAY is an analog transmitter for potentiometric sensors. It converts the mechanical linear or rotational movement into a proportional analog output signal. Two outputs are available, 0 - 10V and 0/4 - 20mA. The current output can be set for 0 or 4mA inside the transmitter.

OC35P-DAY has very high accuracy and stability. Potentiometric sensors between 1k Ω and 100k Ω can be connected. For rotative sensors the output signal can be calibrated in degrees e.g. 0 ... 345 ° = 4 - 20mA.

The connected sensor is supplied with a stable voltage reference. Very high input impedance of the transmitter assures very small current flowing through the potentiometer's rider.

Fast response time makes the transmitter suitable for applications in which the generated signal has to follow very fast the mechanical movements of the sensor.

The transmitter is supplied with 24VDC and is enclosed in a cabinet for DIN 35mm rails. The connection is via screw terminals.

SPECIFICATIONS

Input:	1k Ω - 100k Ω potentiometric sensors with three terminals.
Input Impedance:	10 G Ω .
Voltage Output:	0 - 10V, max. load of 10k Ω . Response time 5ms.
Current Output:	0/4-20mA, load 0 ... 300 Ω . 0 or 4mA are selectable.
Accuracy:	\pm 0.1% from range.
Tempco:	25ppm/K.
Excitation:	1.235V, max. load 1mA.
Supply:	24VDC \pm 10%, 2W.
Case:	25 x 60 x 70mm, weight 75g.
Terminals:	Screw terminals



Model with front adjustments

CALIBRATION – Transmitters with internal adjusting elements

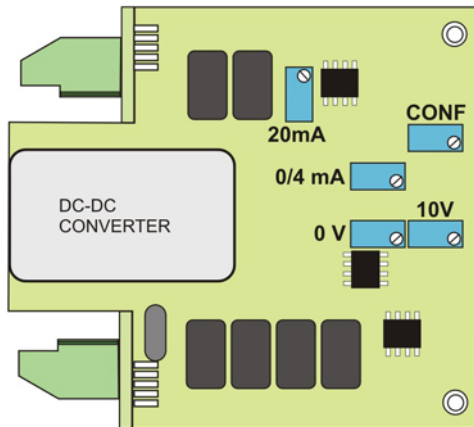

CALIBRATION – Transmitters with front adjusting elements

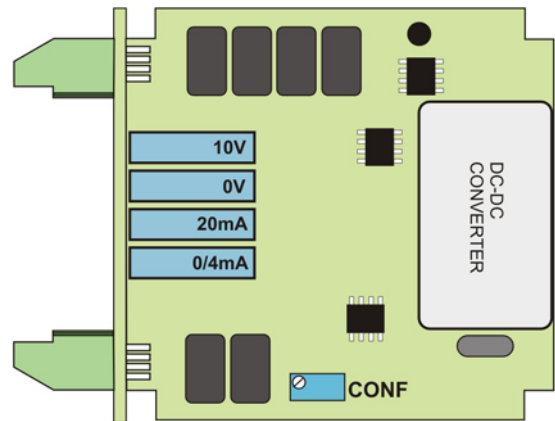

Calibration Steps

The transmitter has been precisely calibrated at the factory. When recalibration is required, follow the next steps:

1. Connect the sensor and set it to zero position, corresponding to output signals 0V and 0mA or 4mA
2. Adjust **0V** for 0V at the output.
Adjust **0/4 mA** for 0mA or 4mA at the output, whatever required.
3. Set the sensor for the maximum displacement, corresponding to 10V and 20mA.
4. Adjust **10V** for the output of 10.00V.
Adjust **20mA** for the output of 20.00mA.
5. Adjust **CONF** to obtain the same output current of 20mA with or without a resistor of 270 Ohm connected externally to the current output.

Repeat the calibration steps when required.

Example: Transmitter connected to linear displacement sensor OCNT 25

